

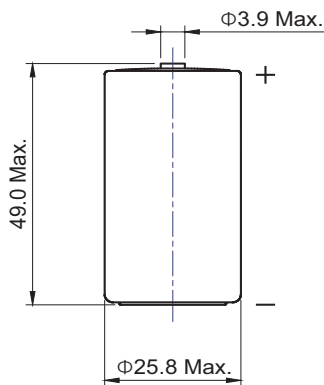

SPECIFICATIONS	
(Typical values stored at 20°C for one year)	
Nominal Capacity (at 3mA/20°C/68°F/2.0V Cut-Off)	8.5Ah
Nominal Voltage	3.6V
Maximum Continuous Current	230mA
Maximum Pulse Current	400mA
Operating Temperature Range	-55~85°C
Weight	49g
Volume	26.0cm ³
UL Approval	MH28122

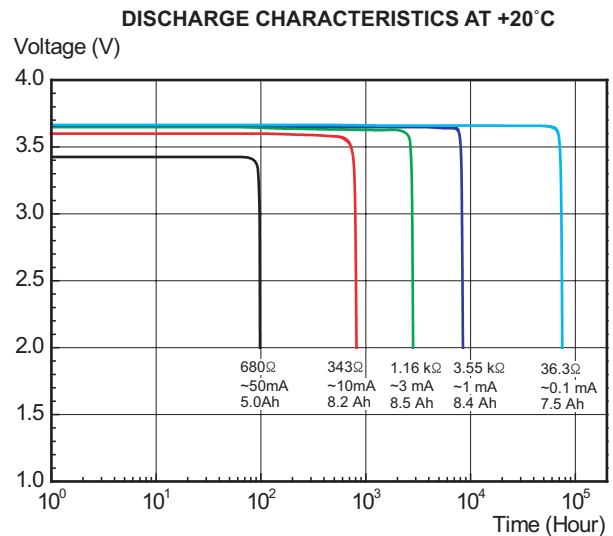

DIMENSIONS IN MM

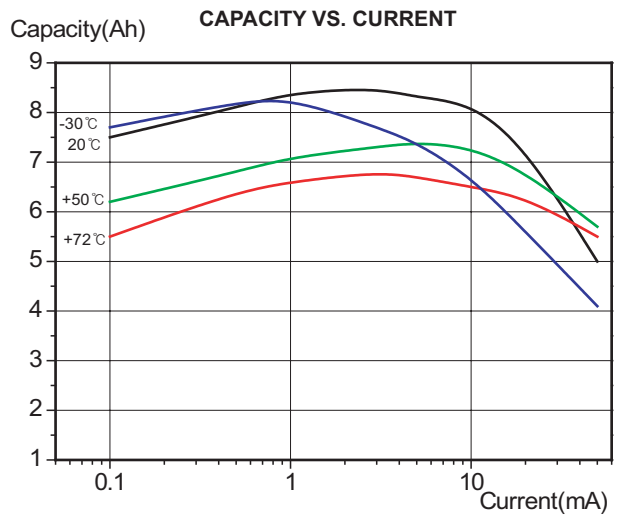

Available Terminal Type :
STD, T1, AX, Wire,
Connector Type

